

IF SERVICES TERMINATE THROUGH THE FLOOR THEY MUST BE WITHIN THE FLOOR SERVICES AREA (400 x 150MM)

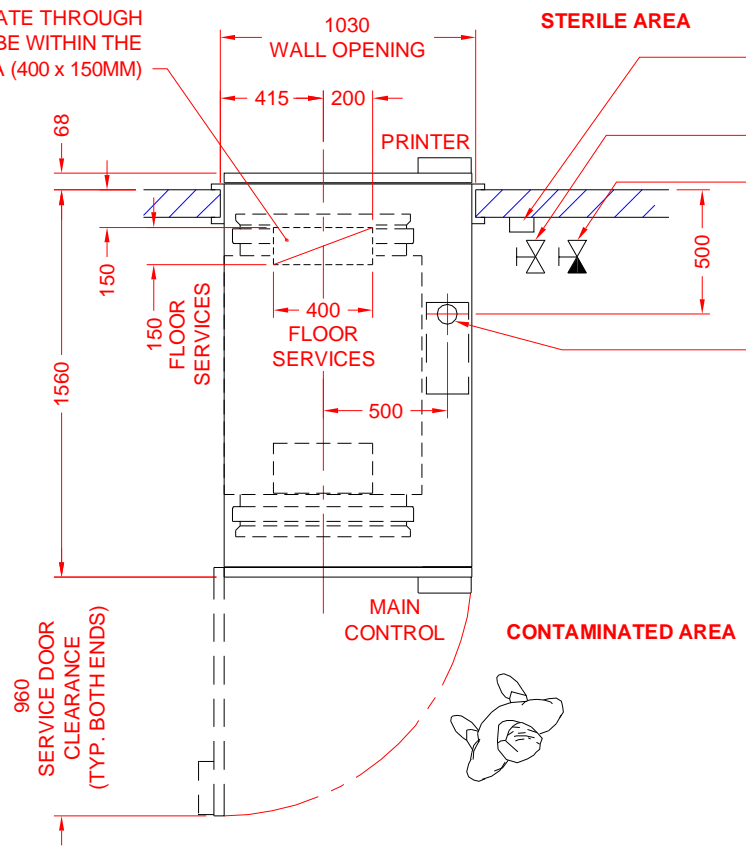



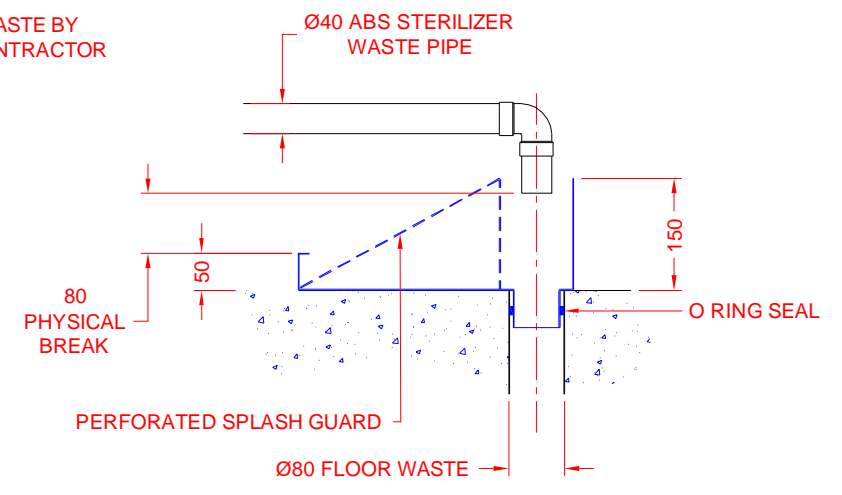

PLAN VIEW

POWER OUTLET SUPPLIED BY ELECTRICAL CONTRACTOR
STEAM SUPPLY WITH ISOLATING VALVE SUPPLIED BY PLUMBING CONTRACTOR
COLD WATER WITH ISOLATING VALVE SUPPLIED BY PLUMBING CONTRACTOR

Ø80 FLOOR WASTE BY PLUMBING CONTRACTOR



SERVICE REQUIREMENTS BY OTHERS

-  **STEAM** - SUPPLY TO BE BETWEEN 400 & 600 KPA AT 0.97 DRYNESS FACTOR, CHLORIDE FREE COMPLETE WITH 20MM ISOLATING VALVE. AVERAGE STEAM CONSUMPTION IS APPROXIMATELY 50 KG/HR WITH A MAXIMUM CONSUMPTION OF 85 KG/HR FOR 3 MINUTES PER CYCLE.
-  **COLD WATER** - SUPPLY TO BE CONSTANTLY BETWEEN 200 & 500 KPA, MAXIMUM TEMPERATURE 25°C, TREATED IF OVER 2 PPM (0.02MMOLL) HARDNESS, CHLORIDE FREE, COMPLETE WITH 15MM ISOLATING VALVE & BACK FLOW PREVENTION TO AS 3500.1. AVERAGE WATER CONSUMPTION IS APPROXIMATELY 16 LITRES/MIN WITH A MAXIMUM OF 18 LITRES/MIN FOR 3 MINUTES PER CYCLE.
-  **WASTE** - Ø80MM TO SEWER IN COMPLIANCE WITH AS 3500.2. AVERAGE WASTE OUTLET TEMPERATURE 50°C WITH A MAXIMUM OF 100°C SHORT TERM. ATHERTON SUPPLIED TUNDISH TO BE LOCATED OVER WASTE POINT. Ø40 STERILIZER DISCHARGE ABS PIPE MUST DISCHARGE INTO TUNDISH WITH 80MM PHYSICAL AIR BREAK.
-  **POWER** - TO AS 3000. 3 PHASE, NEUTRAL & EARTH, 32 AMPS PER PHASE. ATHERTON RECOMMENDS "CLIPSAL 56S0532" 5 PIN OUTLET & "CLIPSAL 56SW332" SWITCH.

VENTILATION - ATHERTON RECOMMENDS VENTILATION OF THE STERILIZER ROOM FOR THE REMOVAL OF HEAT.

FLOOR WASTE - ATHERTON RECOMMENDS THE INSTALLATION OF A CORRECTLY DRAINED FLOOR WASTE TO HELP REDUCE POTENTIAL DAMAGE IN CASE OF A MAJOR STEAM OR WATER LEAK.

PRODUCT CODE & SPECIFICATIONS
TSCD6612 - TANGENT SERIES TIGER, RETICULATED STEAM, CABINET, DOUBLE DOOR STERILIZER.
 CHAMBER DIMENSION: 660 x 660 x 1300MM DEEP.
 HEAT LOSS FRONT OF WALL AT 21°C : 1150 WATTS.
 HEAT LOSS FROM CABINET AT 21°C : 3350 WATTS.
 OPERATING WEIGHT (CHAMBER FILLED WITH WATER) : 1500 KG
 PACKED WEIGHT : 1150 KG
 STRIP DOWN SIZE : 820 WIDE x 1660 HIGH x 1560MM LONG

GENERAL NOTES
 ALL DIMENSIONS ARE IN MM.
 GENERAL TOLERANCE ON BUILDING ±5MM.
 ALL SERVICE SPECIFICATIONS ARE DYNAMIC.
 SERVICES AND BUILDING REQUIREMENTS ARE TO BE SUPPLIED BY THE CLIENT UNLESS OTHERWISE SPECIFIED.

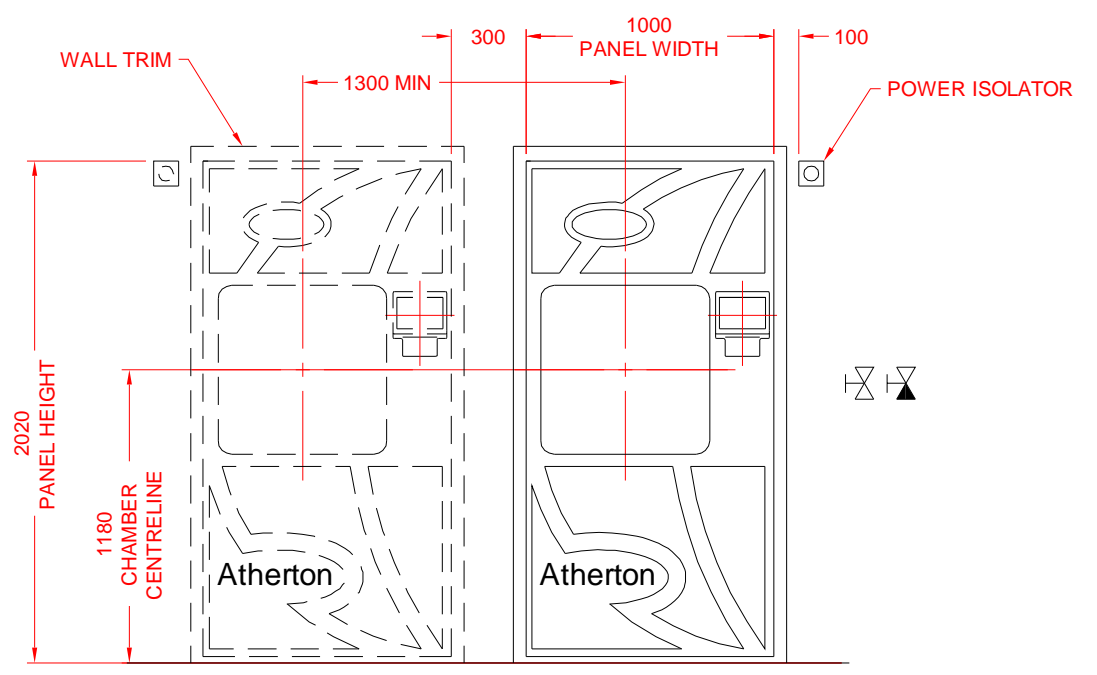

FRONT ELEVATION

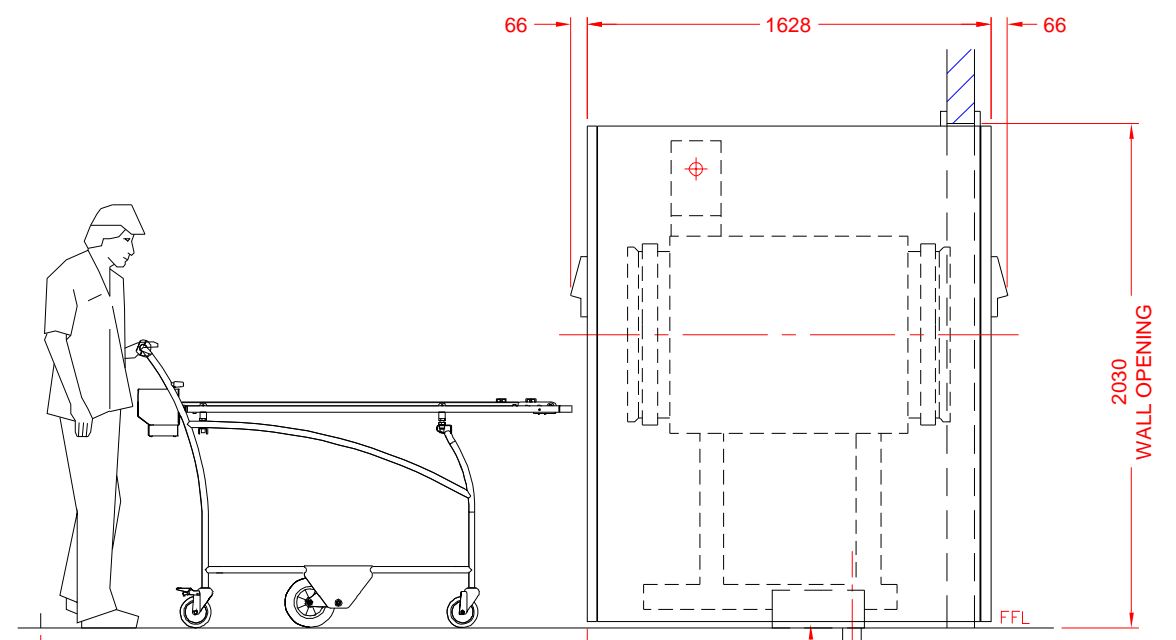

SIDE ELEVATION

Atherton

STERILIZER INSTALLATION DETAILS

TSCD6612 TANGENT SERIES TIGER STERILIZER

CLIENT APPROVAL

PROJECT.....

APPROVED BY.....

(PRINT NAME).....

SIGNED..... DATE.....

SPECIAL REQUIREMENTS

IF DRAWING IS NOT RETURNED WITHIN 30 DAYS, ATHERTON WILL ASSUME THAT ALL SERVICES & SPACE REQUIREMENTS HAVE BEEN PROVIDED. ATHERTON TAKES NO RESPONSIBILITY FOR DELAYS, COSTS OR DAMAGE TO EQUIPMENT IF PURCHASER DOES NOT SUPPLY SERVICES AS DETAILED IN THIS DOCUMENT AND WARRANTY COVER MAY BE VOID.

DRAWN. P.L.G.	DATE. 09/11/2011		APPROVED.
DOCUMENT NO.	REV NO.	SHEET SIZE	SCALE
025205	2	A3	1:30
			DATE. 14/11/2011
			R.OLIVER