





SERVICE REQUIREMENTS BY OTHERS

- 
STEAM - SUPPLY TO BE BETWEEN 400 & 500 KPA AT 0.97 DRYNESS FACTOR, CHLORIDE FREE COMPLETE WITH 20MM ISOLATING VALVE. AVERAGE STEAM CONSUMPTION IS APPROXIMATELY 70 KG/HR WITH A MAXIMUM CONSUMPTION OF 110 KG/HR FOR 3 MINUTES PER CYCLE.
- 
COLD WATER - SUPPLY TO BE CONSTANTLY BETWEEN 200 & 500 KPA, MAXIMUM TEMPERATURE 25°C, TREATED IF OVER 2 PPM (0.02 MMOL/L) HARDNESS, CHLORIDE FREE, COMPLETE WITH 20MM ISOLATING VALVE & BACK FLOW PREVENTION TO AS 3500.1. AVERAGE WATER CONSUMPTION IS APPROXIMATELY 18 LITRES/MIN WITH A MAXIMUM OF 22 LITRES/MIN FOR 3 MINUTES PER CYCLE.
- 
WASTE - Ø80MM TO SEWER IN COMPLIANCE WITH AS 3500.2. AVERAGE WASTE OUTLET TEMPERATURE 50°C WITH A MAXIMUM OF 100°C SHORT TERM. ATERTON SUPPLIED TUNDISH TO BE LOCATED OVER WASTE POINT. Ø40MM STERILIZER ABS PIPE MUST DISCHARGE INTO TUNDISH WITH 80MM PHYSICAL AIR BREAK.
- 
POWER - TO AS 3000. 3 PHASE, NEUTRAL & EARTH, 32 AMPS PER PHASE. ATHERTON RECOMMENDS "CLIPSAL 56S0532" 5 PIN OUTLET & "CLIPSAL 56SW332" SWITCH.

VENTILATION - ATHERTON RECOMMENDS VENTILATION OF THE STERILIZER FOR THE REMOVAL OF HEAT.

FLOOR WASTE - ATHERTON RECOMMENDS THE INSTALLATION OF A CORRECTLY DRAINED FLOOR WASTE TO HELP REDUCE POTENTIAL DAMAGE IN CASE OF A MAJOR STEAM OR WATER LEAK.

PRODUCT CODE & SPECIFICATIONS
 CSB9612 - CYBER SERIES CHINCHILLA, RETICULATED STEAM, BUILT IN STERILIZER.
 CHAMBER DIMENSION : 900 x 660 x 1300MM DEEP.
 HEAT LOSS FRONT OF WALL AT 21°C : 1450 WATTS.
 HEAT LOSS BACK OF WALL AT 21°C : 2800 WATTS.
 OPERATING WEIGHT (CHAMBER FILLED WITH WATER) : 1850 KG
 PACKED WEIGHT : 1400 KG
 STRIP DOWN SIZE : 820 WIDE x 1700 HIGH x 1650MM LONG.

GENERAL NOTES
 ALL DIMENSIONS ARE IN MM.
 GENERAL TOLERANCE ON BUILDING ±5MM.
 ALL SERVICE SPECIFICATIONS ARE DYNAMIC.
 SERVICES AND BUILDING REQUIREMENTS ARE TO BE SUPPLIED BY THE CLIENT UNLESS OTHERWISE SPECIFIED.

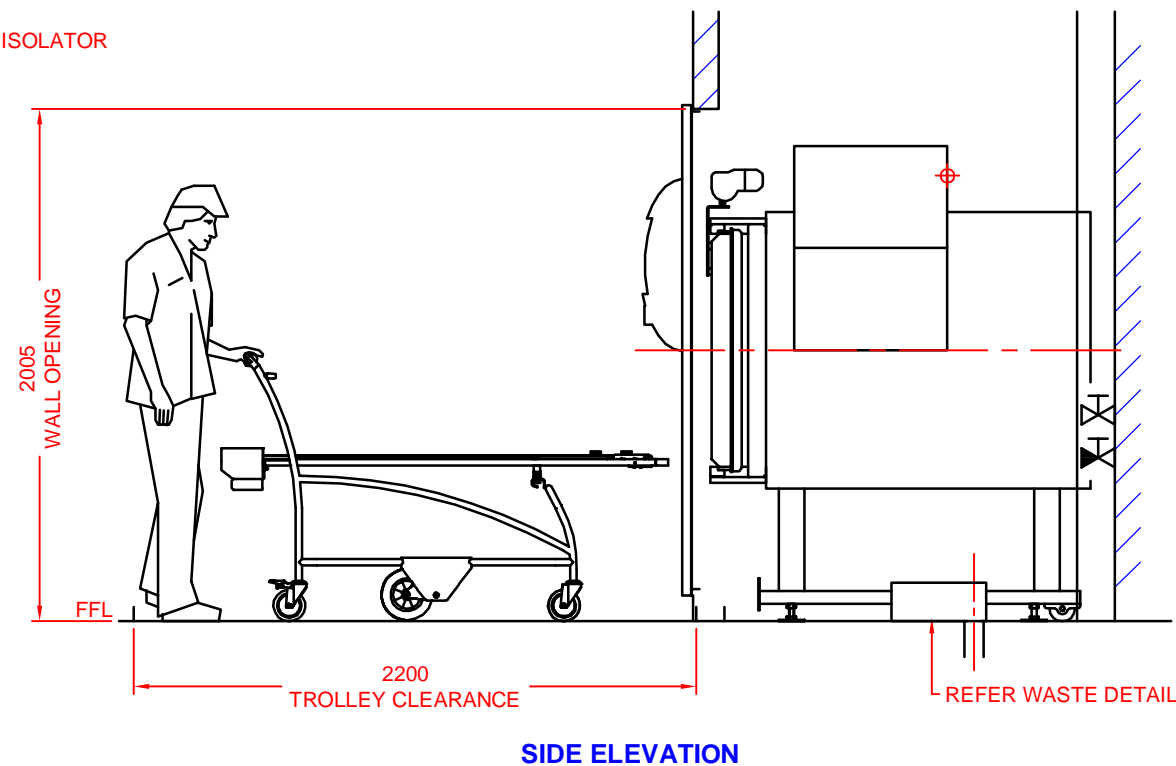
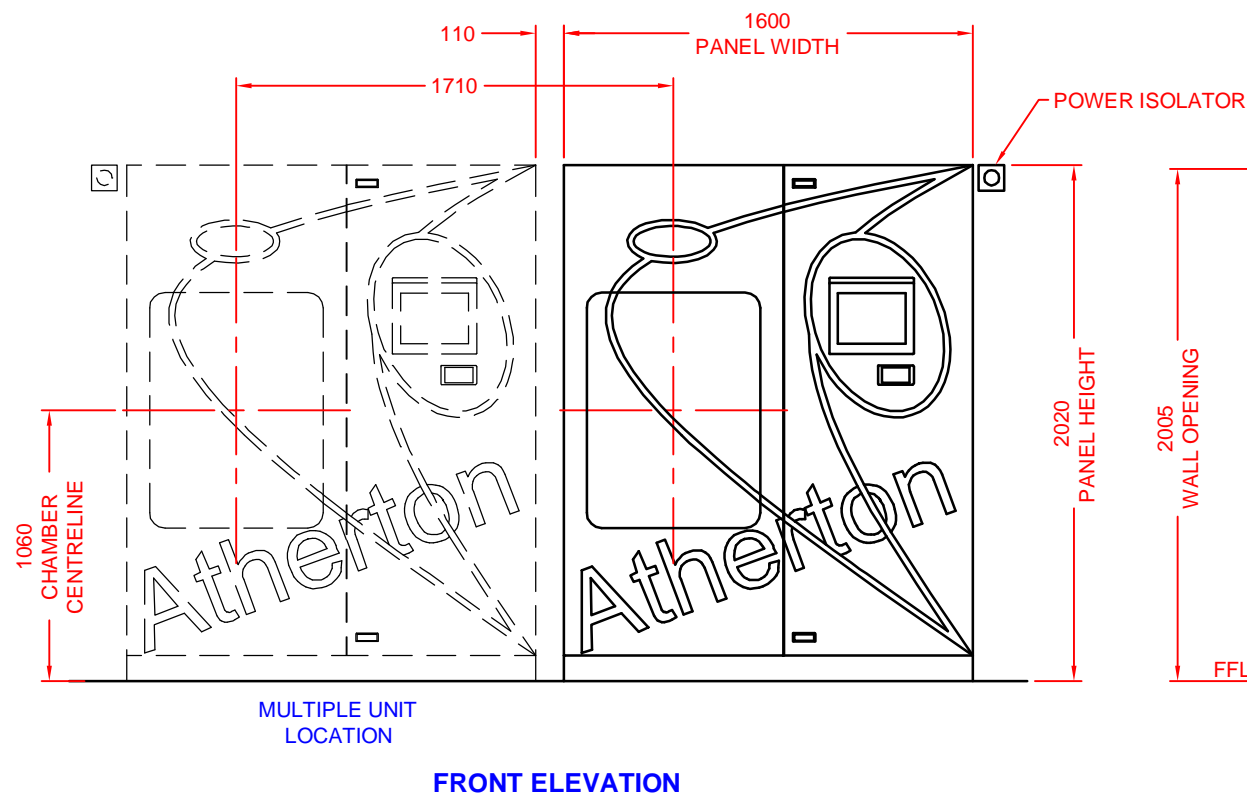

Atherton

STERILIZER INSTALLATION DETAILS

CSB9612 CYBER SERIES CHINCHILLA STERILIZER

CLIENT APPROVAL

PROJECT.....
 APPROVED BY (PRINT NAME).....
 SIGNED..... DATE.....

SPECIAL REQUIREMENTS

IF DRAWING IS NOT RETURNED WITHIN 30 DAYS, ATHERTON WILL ASSUME THAT ALL SERVICES & SPACE REQUIREMENTS HAVE BEEN PROVIDED. ATHERTON TAKES NO RESPONSIBILITY FOR DELAYS, COSTS OR DAMAGE TO EQUIPMENT IF PURCHASER DOES NOT SUPPLY SERVICES AS DETAILED IN THIS DOCUMENT AND WARRANTY COVER MAY BE VOID.

DRAWN. P.L.G.	DATE. 09/11/2011	APPROVED. R.OLIVER
DOCUMENT NO. 025215	REV NO. 2	DATE. 14/11/2011
SHEET SIZE A3	SCALE 1:30	