







# Atherton

## Duck Series



### FEATURES

-  Front access for maintenance.
-  240 Volt 10 Amp GPO connection.
-  Chamber capacity: 2 Urinal or 1 Bedpan.
-  Cool down stage (no hot pans/bottles).
-  Stainless steel construction of panels, frame, water tank and hopper.
-  No vent or tank overflow required.



Ducks like water and need water to live. We like Ducks and water too. So we designed the Duck Series Bedpan and Urine bottle flusher/sanitizer to use as little water as possible, and still clean what needs to be cleaned. There is even an “eco cycle” to take care of the number one stuff, and the normal cycle for number two jobs.

How did we do it, you ask? Well, we improved the design of our cleaning spray system so it works better and uses less water in the process. We also decided to get all steamed up when it came to the sanitizing part of the exercise, literally. Instead of using a lot of hot water (boiling hot actually) which consumes a lot of electricity to make, we use a little electricity to make a lot of steam, to make the bedpan hot (more than 85 °C) which makes everyone happy except the bugs we are trying to get rid of. They're not happy at all, but who cares. We use so little electricity in fact, you can use a standard 10 amp GPO to run the machine compared to three phase power of the old model. We got quite a buzz out of achieving that, and using a lot less electricity can't be a bad thing, right?

But all that stuff is buried behind the panels. What looks different from the outside? Well for one thing the unit is smaller (shorter to be precise), and it has a touch screen to let you know what is happening with the cycle, what sort of day/week/month the unit has had (in the shape of a fault report) and other intriguing stuff that service technicians just love to play around with.

The door still opens and closes by itself, courtesy of the motion sensor which tells the controls (microprocessor based of course) that someone is waving a bedpan around that they would like to get rid of, sooner rather than later. Once you have gotten rid of the pan, a simple tap on the touch screen gets things moving, so to speak, and before you know it, the jobs done!

**Automatic Bed Pan Flusher/Sanitizer**

Atherton is a dynamic and innovative organization operating nationally within Australia, with an office in each capital city, and internationally through its network of agents throughout Asia and the Pacific nations.

To find out more about Atherton Sterilizers and other infection control products Visit our web site [www.atherton.net](http://www.atherton.net) Alternatively phone our office.

Established in 1889, Atherton is a privately owned family business.

## TECHNICAL DATA

### SERVICES

- **Cold Water** - 15mm BSP connection, 250-350Kpa.
- **Waste** - 100mm Connection. "S" or "P" trap. Connection to AS3500.2  
Waste discharge temperature not more than 45°C
- **Power** - 10 Amp GPO to AS3000.

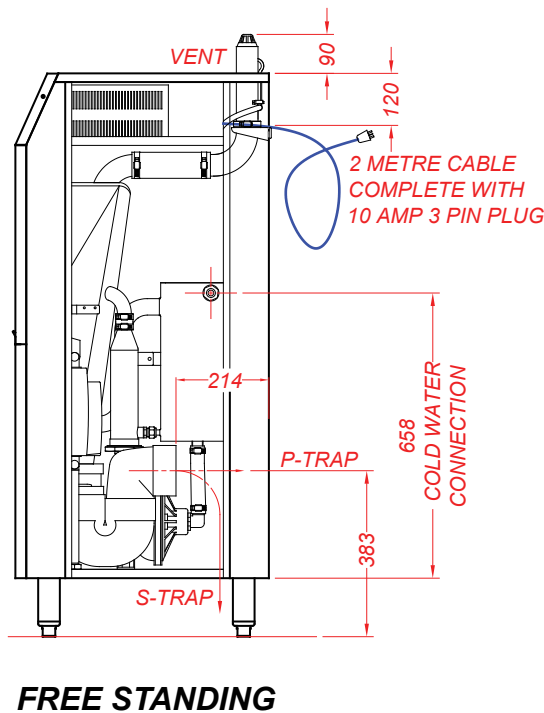
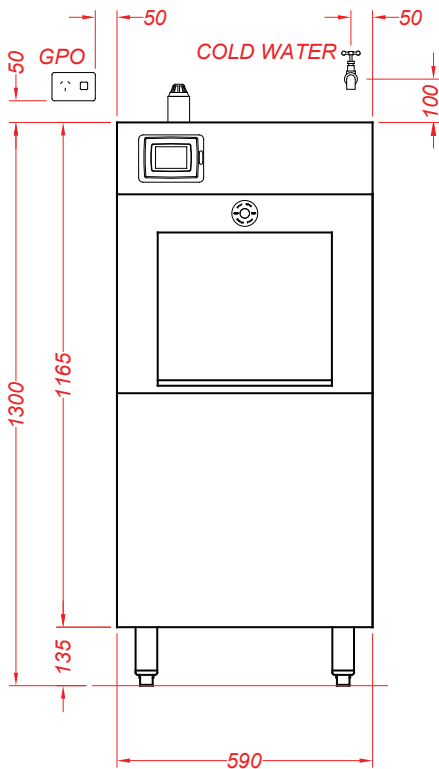
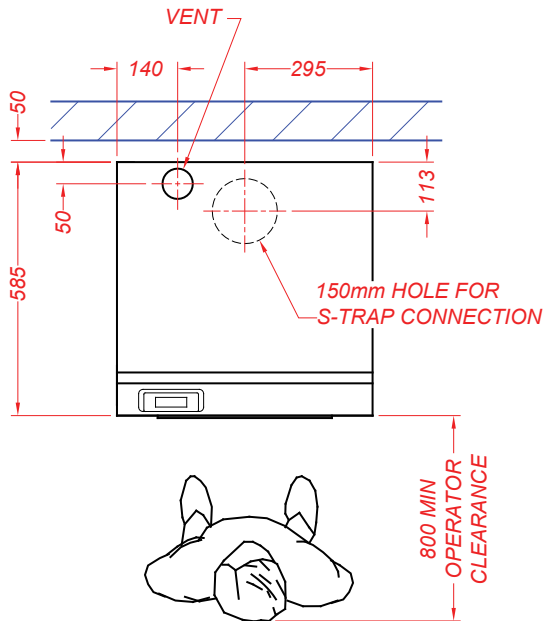

**FREE STANDING**

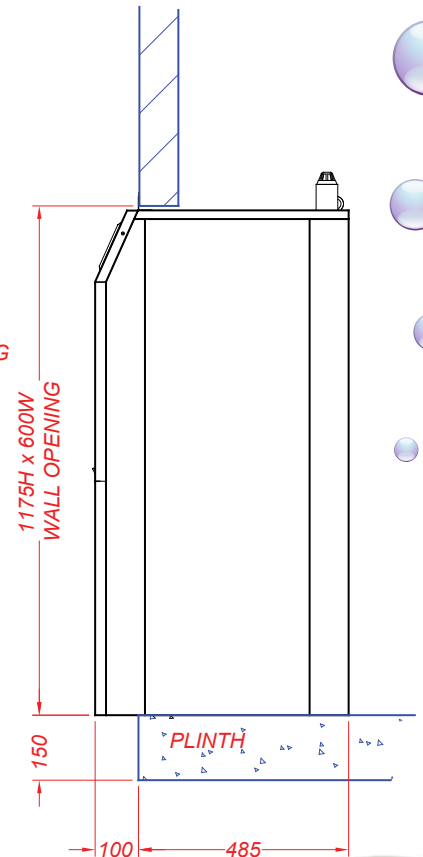

**BUILT IN**

Adelaide

Brisbane

Melbourne

Perth

Sydney

Fax +61 3 9497 1190

Email [info@atherton.net](mailto:info@atherton.net)

Sales & Service 1300 580 870

General Enquiries +61 3 9497 2500

Head Office 364 Darebin Road, Thornbury Vic 3071, Australia.

Design and specifications may change without notice.

TDS 129 Revision:2 09/08/10.

**"Committed to quality since 1889"**

Web: [www.atherton.net](http://www.atherton.net)

A.E. ATHERTON & SONS PTY. LTD. ACN 004 104 607 ABN 54 004 104 607

